

## IH8 Series Camera Enclosure

### Installation/Operation Manual C439M - 10/92

#### 1.0 SCOPE

The information contained within this manual covers the IH8 Series camera enclosure with integral mount.

#### 1.1 WARNING

To insure safe operation, observe the following guidelines:

1. Installation shall be done by qualified service and installation personnel.
2. Installation shall be done in accordance with all local and national electrical and mechanical codes utilizing only approved materials.
3. Use only installation methods and materials capable of supporting four (4) times the maximum specified load.
4. Unless the unit is specifically marked as a NEMA Type 3-6P enclosure, it is designed for Indoor use only and it must not be installed where exposed to rain and moisture.

5. Only use replacement parts recommended by Pelco.

Please thoroughly familiarize yourself with the information in this manual prior to installation and operation.

#### 2.0 DESCRIPTION

The IH8 Series is a light duty camera enclosure with integral mount designed for indoor use. The IH8 Series can be used with 1/3-inch and 1/2-inch cameras and will accommodate fixed focal length lenses with or without auto-iris operation up to 5 inches in length.

This enclosure has a clamshell cover for easy access when installing or servicing the camera/lens. Also included in the unique design of this enclosure is a cable feedthrough hole, a slotted camera bracket, and an integral mount. The IH8 Series enclosure is constructed of .074 ABS plastic and the integral mount is aluminum.

## 2.1 MODELS

IH8-B	Light duty, indoor camera enclosure with integral mount for fixed mounting applications, black finish
IH8-W	Light duty, indoor camera enclosure with integral mount for fixed mounting applications, white finish

Cable Entry: Two (2) .593" diameter holes (one in the enclosure and one in the mount)

Suggested Mounting Method: Secure to solid mounting surface with four fasteners of a suitable size (suggested minimum 1/4" diameter, not supplied)

Construction: .074 ABS plastic/aluminum

Finish: Housing: Textured black or white  
Mount: Powder coated black or white

## 3.0 SPECIFICATIONS

Camera Mounting: Slotted camera bracket

Enclosure Positioning: Swivel mount allows enclosure to be positioned 0–180° horizontally or vertically

Dimensions: See Figure 1

Maximum Load: 2 lbs (.9 kg)

Maximum Camera/Lens Size: Accommodates camera/lens combinations (including BNC connector) up to: 2.75" W x 2.50" H x 5.00" L

Approximate Weight: 7.5 oz

Viewing Window: 1/8" thick, optically clear, impact resistant Lexan. Viewing area 2-1/2" diameter

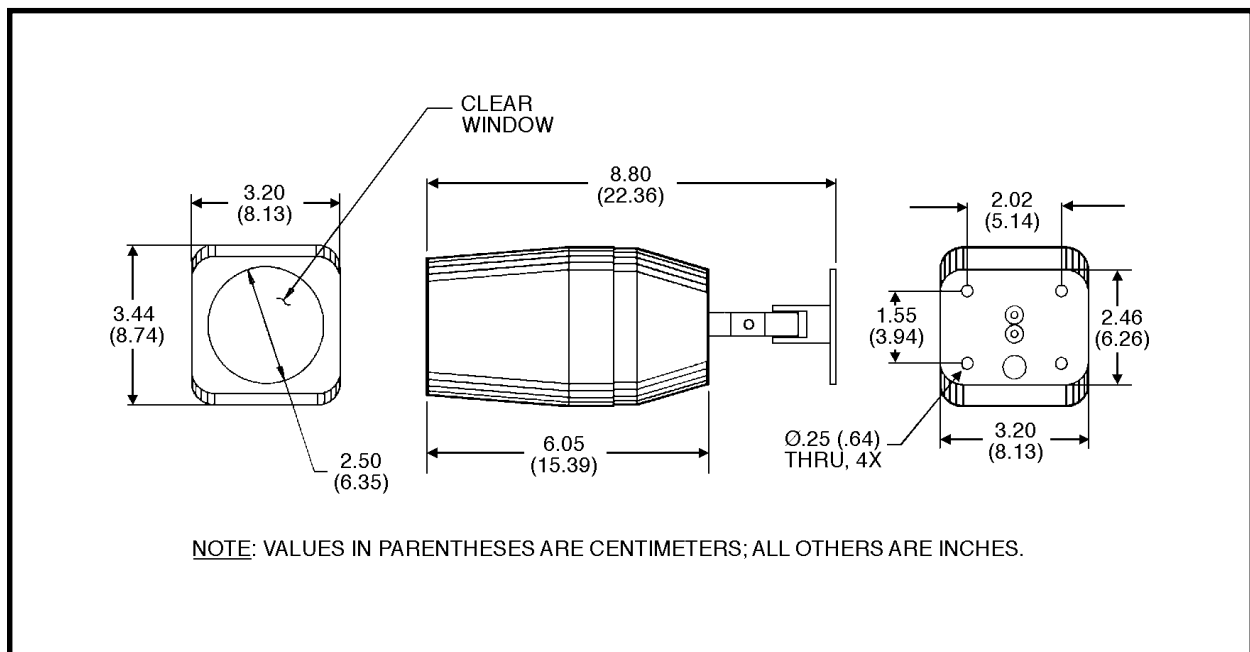

Figure 1. Dimension Drawing

## 4.0 INSTALLATION

Note: Fasteners to secure the enclosure to a load-bearing solid surface are not supplied.

To install the camera/lens, perform the following:

1. Using the mount as a template, mark and drill holes in the mounting surface. (If you are planning to conceal the wiring through the mounting surface you will also need to mark and drill the cable feedthrough hole at this time.) Attach the enclosure with integral mount securely to the mounting surface with fasteners of a suitable size (1/4-20 screws recommended, not supplied).
2. Gently pull the front of the housing to separate the two halves of the enclosure.
3. Place the camera/lens onto the slotted camera bracket and secure with the 1/4-20 screw provided.
4. Route the coax through the cable feedthrough hole located on the rear of the enclosure. (If desired, the coax can also be routed through the feedthrough hole on the mount to conceal the wiring through the mounting surface.)
5. If necessary, shim up the camera/lens using flat washers (not provided) to ensure the camera/lens is in the center of the viewing window.
6. Adjust the camera/lens (front to back) so that the lens is as close to the viewing window as possible.
7. Replace front cover.

## 5.0 WARRANTY AND RETURN INFORMATION

### WARRANTY

PELCO will repair or replace, without charge, any merchandise proved defective in material or workmanship for a period of one year after the date of shipment (six months on all pan and tilts with auto scan and medium duty scanners, and two years on Legacy®, Intercept® and CM9500/CM8500 Matrix products). PELCO will warranty all replacement parts and repairs for 90 days from the date of shipment. All goods for warranty work shall be sent freight prepaid to our Clovis, California facility. Repairs made necessary by reason of misuse, alteration, normal wear, or accident are not covered under this warranty. PELCO is not liable for any incidental or consequential expenses or liability incurred by the customer as a result of field repair, installation, or any other reason.

The above warranty is in lieu of any other expressed or implied warranty, condition, or guarantee by PELCO of the equipment listed herein. PELCO makes no warranties except for intended use and will not be liable for any loss, damage, or costs arising, whether consequential or incidental, from the use of said merchandise.

This warranty gives you specific legal rights. You may also have additional rights, which are subject to variation from state to state.

If a warranty repair is required, contact PELCO at (800) 289-9100 or (559) 292-1981 for a Repair Authorization number (RA), and provide the following information:

1. Model and serial number
2. Date of shipment, P.O. number, Sales Order number, or PELCO invoice number
3. Details of the defect or problem

If there is a dispute regarding the warranty of a product which does not fall under the warranty conditions stated above, please include a written explanation with the product when returned.

Ship freight prepaid to: PELCO  
300 West Pontiac Way  
Clovis, CA 93612-5699

Method of return shipment shall be the same as method by which the repair item is received by PELCO.

### RETURNS

In order to expedite parts returned to the factory for repair or credit, please call the factory at (800) 289-9100 or (559) 292-1981 to obtain an authorization number (CA number if returned for credit, and RA number if returned for repair). Goods returned for repair or credit should be clearly identified with the assigned CA/RA number and freight should be prepaid. All merchandise returned for credit may be subject to a 20% restocking and refurbishing charge.

Ship freight prepaid to: PELCO  
300 West Pontiac Way  
Clovis, CA 93612-5699



PELCO  
300 West Pontiac Way  
Clovis, CA 93612-5699 USA  
(559) 292-1981 • (800) 289-9100  
FAX (800) 289-9150 or (559) 292-3827  
DataFAX (800) 289-9108 or (559) 292-0435

International customers call 1-559-292-1981 or  
FAX 1-559-348-1120

(Product specifications subject to change  
without notice.)

C439M